

2/2

ANNEXURE-1

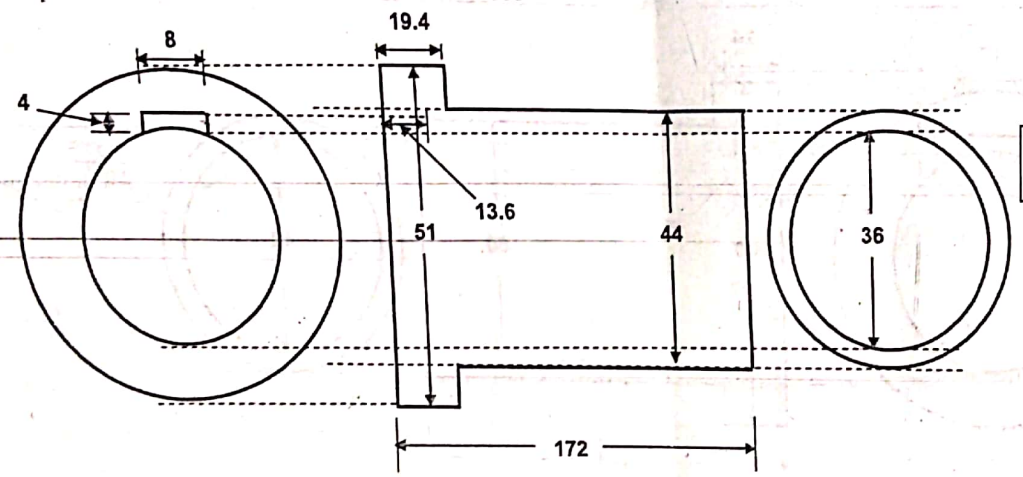
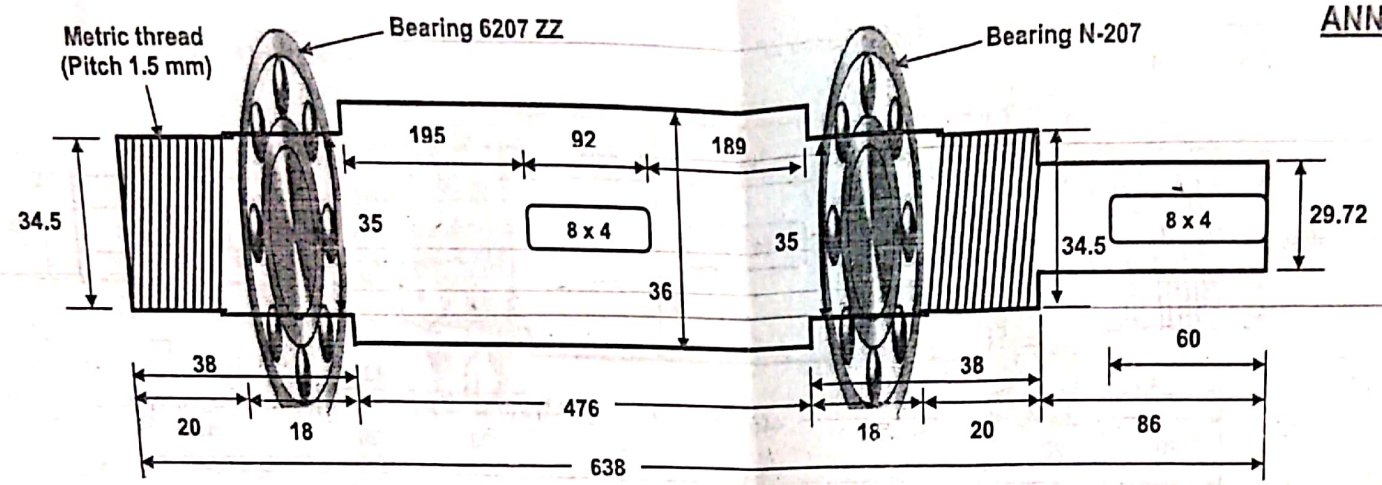

NOTE:
All dimensions in mm

ROUGH SKETCH OF SHAFT & SHAFT SLEEVE OF BEST & CROMPTON MAKE PUMP MODEL: BWC 80/100 - 300, CAPACITY 100 M³/HR., HEAD 30 MWC, RPM-1470, HORIZONTAL, SINGLE-STAGE

Handwritten signature

2/13

ANNEXURE-2

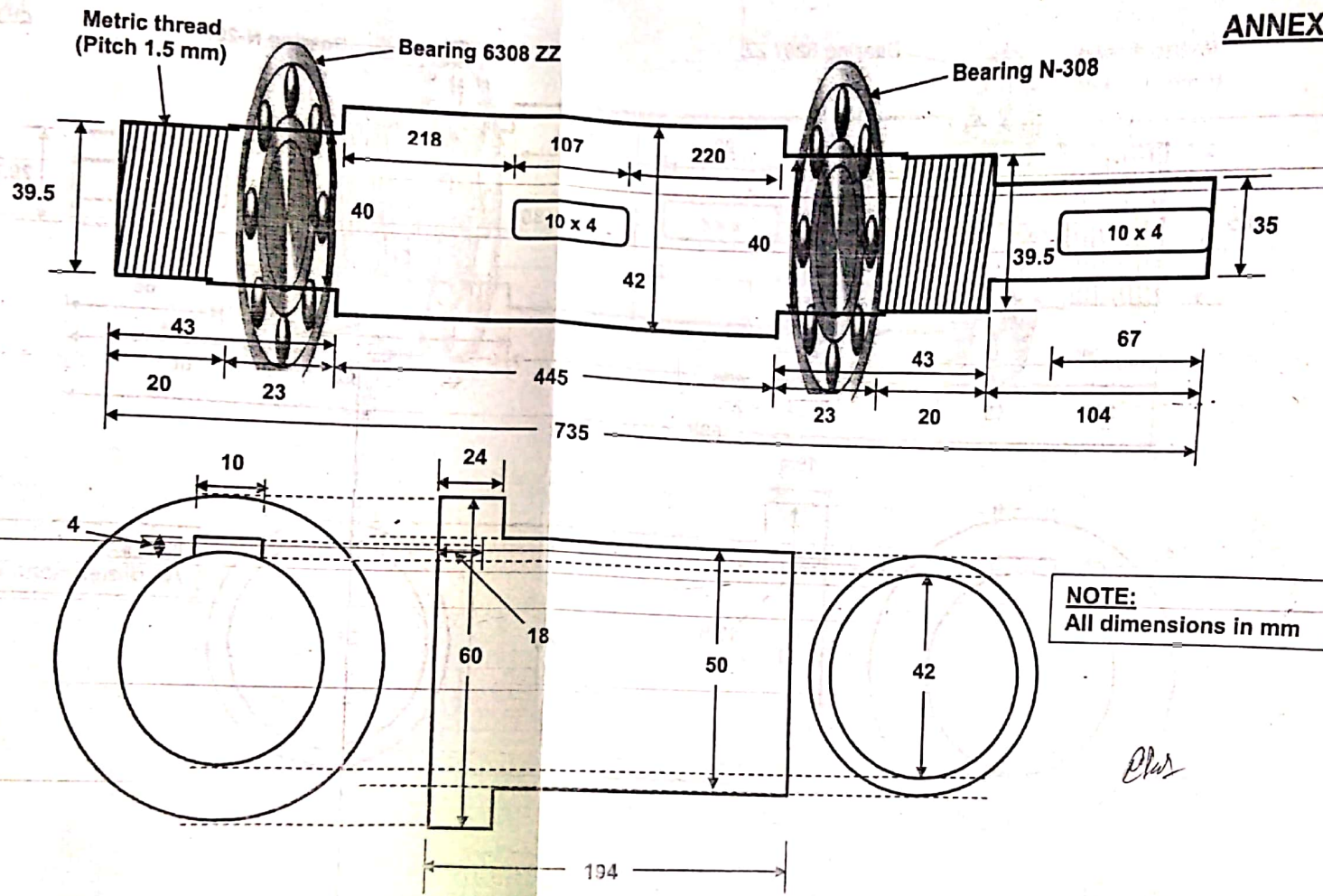

NOTE:
All dimensions in mm

Plus

**ROUGH SKETCH OF SHAFT & SHAFT SLEEVE OF BEST & CRAMPTON MAKE PUMP MODEL: SDC
100/125, CAPACITY 30 M³/HR., HEAD 40 MWG, RPM-1470, HORIZONTAL, SINGLE-STAGE**

25/2

ANNEXURE-3

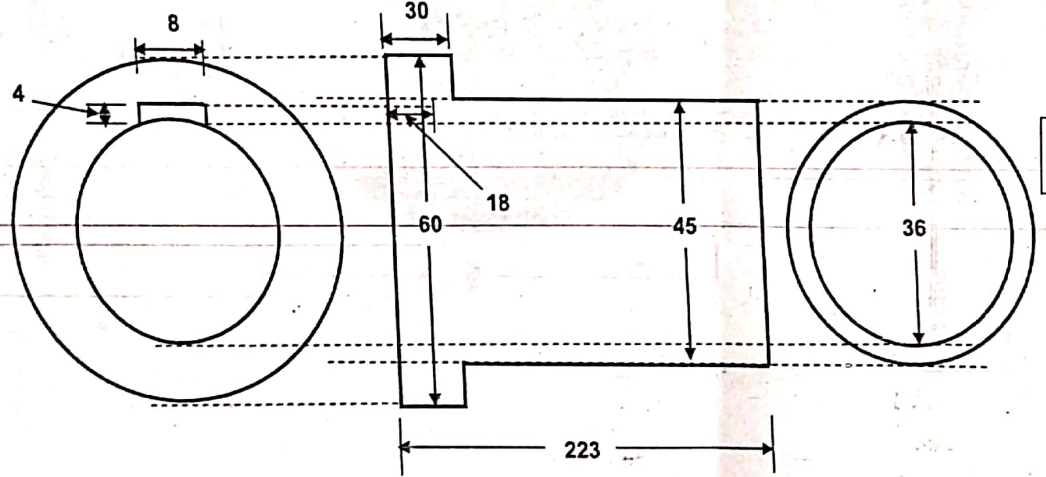
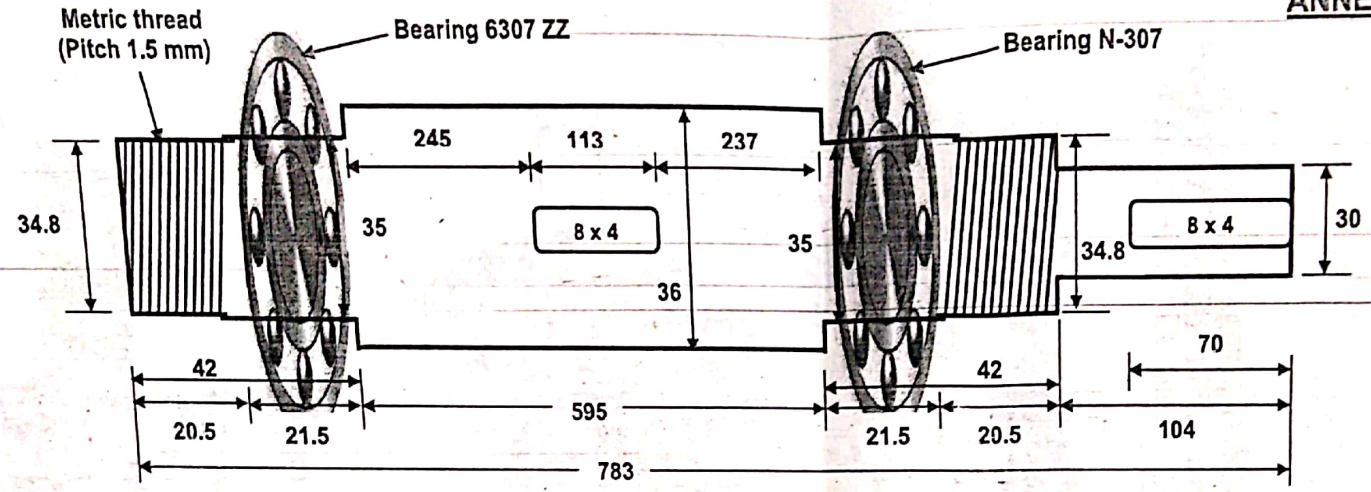

NOTE:
All dimensions in mm

ROUGH SKETCH OF SHAFT & SHAFT SLEEVE OF BEST & CROMPTON MAKE PUMP MODEL: SDB-150/200, CAPACITY 300 M³/HR, HEAD 30 MWC, RPM-1470, HORIZONTAL, SINGLE-STAGE

ANNEXURE-4

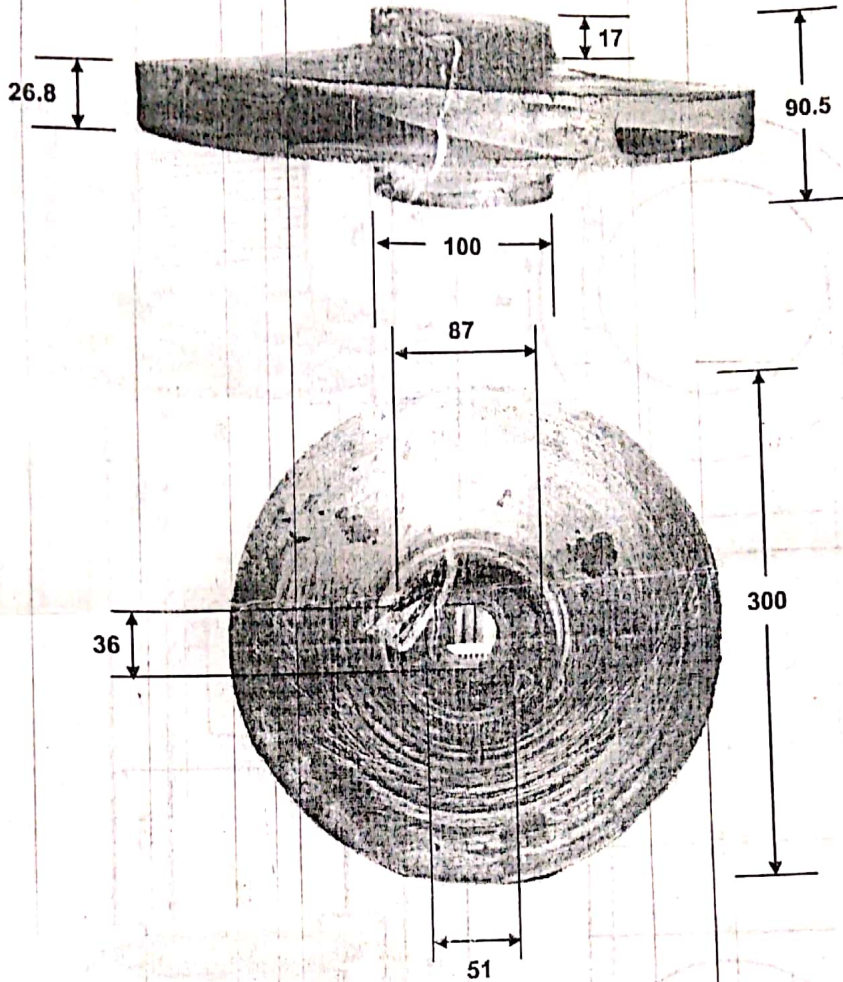

NOTE:

1. No. of vanes = 08
2. Keyway = 8 x 4 mm
3. Double suction, closed impeller
4. All dimensions in mm

**ACTUAL IMAGE OF IMPELLER OF BEST & CROMPTON
MAKE PUMP MODEL: BWC 80/100 - 300, CAPACITY 100 M³/HR.,
HEAD 30 MWC, RPM-1470, HORIZONTAL, SINGLE-STAGE.**