



# Punjab State Power Corporation Limited

(Regd. Office :PSEB Head Office, The Mall Patiala - 147001,  
Corporate Identity Number : U40109PB2010SGC033813 Website www.pspcl.in

OFFICE OF THE CHIEF ENGINEER/GGSSTP,  
MATERIAL MANAGEMENT CELL-III, V&P.O. GHANAULI, ROOPNAGAR-140113  
( FAX NO 01881-274232, PH NO 01881-275666)  
(ISO 9001:2000 CERTIFIED)

e-mail : se-monitoring-ggsstp@pspcl.in

43  
1-14

To

Regd./Email

Limited Tender enquiry,  
On various firm's as per overleaf.

Memo No. 757/65 IP-3/EMP-11572

Dated: 3/3/20

Subject: - Procurement of spares for bowl mills of stage-III, GGSSTP,  
Ropar.

Enquiry No. 7168 IP-3/EMP-11572 dated: 3-3-20

Date & Time of Receipt of Tender 31-3-20 upto 11.00 A.M.

Date & Time of Opening of Tender 31-3-20 at 11.30 A.M.

(In case opening date happens to be holiday, tender shall be  
opened on next working date at the same time)

Dear Sirs,

Please send your sealed quotation in duplicate in the  
Performa attached on the firm prices for the supply and delivery of items  
as detailed in Annexure-'A' enclosed. Enquiry No. and date of opening of  
tender must be legibly mentioned at right top corner of sealed cover.  
General terms & conditions shall be as per Annexure-'B' attached. Your  
quotation should be in two parts. For each item, unit rates should be  
quoted strictly on the attached performa of pricing schedule. Please note  
that if quoted rates are not as per attached performa, the offer is liable to  
be rejected. Insurance and freight charges should be quoted separately.

Also please note that competent authority may distribute the  
quantities to be procured on more than one firm.

The offer must be kept valid for atleast 120 days

D/A- Annexure- A, B, technical specification, Annexure I & II  
(sketches), Performa for Schedule of Deviation, Performa of pricing  
schedule

Dy. CC/Monitoring,  
For CE/GGSSTP, Rupnagar

- CC :-
- email {
- 1) Dy.C.E./MMC-II,GGSSTP,Rupnagar along with Annexure-A to check specifications and intimate, if there is any discrepancy please.
  - 2) Dy. CAO,GGSSTP,Rupnagar.
  - 3) Notice Board.



# PUNJAB STATE POWER CORPORATION LIMITED

(Regd. Office : PSEB Head Office, The Mall, Patiala - 147001)  
Corporate identity Number U40109PB2010SGC033813 Website: www.pspcl.in

OFFICE OF THE CHIEF ENGINEER /GGSSTP,  
MATERIAL MANAGEMENT CELL-3, V&P.O. GHANAULI, ROOPNAGAR-140113  
Phone no. 01881-275666 E-mail: se-monitoring-ggsstp@pspcl.in

## Annexure-'A'

ENQUIRY NO. 7168 IP-3/EMP-11572 DT. 3-3-20

### DETAIL OF MATERIAL AND TECHNICAL SPECIFICATIONS

Sr. no.	GGSSTP Code	Description	Qty.
1	08050577	Multiple port outlet fitted with liners for HP-803 mills stage-III.	12
2	08050618	Journal head skirts	6

#### **Terms and Conditions:-**

- 1) Fax/Telegraphic/e-mail tender shall not be accepted.
- 2) The tender shall be sent in two separate envelopes as under:-
  - (a) **Part-1-** One envelope containing deposit of Earnest Money (if applicable) & Technical /Commercial bids.
  - (b) **Part-2-** The other containing the prices.While opening the tenders the envelope containing the Earnest Money (if applicable) & Technical /Commercial shall be opened first and in case the deposit of Earnest Money (if applicable) & Technical /Commercial is in accordance with the terms of notice inviting tender only then second envelope containing the tender (prices) shall be opened.
- 3) **The tender must be accompanied by EARNEST MONEY (If applicable as per Annexure-B)**
- 4) The rates should be quoted on FOR destination basis giving break up of FOR Destination price as per **Performa of pricing schedule** attached.
- 5) The Performa for price schedule enclosed with specification shall be filled by tenderers duly typed and **hand written prices shall not be accepted.**
- 6) In addition to the break-up of total price i.e. ex-works cost, GST, Freight, Insurance and Packing the bidders should also give split up of ex-works price.
- 7) **Split up of ex-works prices shall indicate cost of raw material, Labour component and overhead expenses.**
- 8) Raw material can further be divided into 3-4 parts depending upon type of material.
- 9) The offer should be kept valid for 120 days from date of opening of tenders.
- 10) The bidders are not allowed to indicate over all discounts on the quoted price for which split up has been given as mentioned in Sr. No. 6 & 7 above. However, quantity/payment discount can be given by the tenderer in the main tender.
- 11) Any firm offering discount on the quoted price or after the opening of tender will be out rightly rejected.
- 12) Competent authority may distribute the quantities to be procured on more than one firm.

- 13) All pages of quotation should be duly signed.
- 14) Quantity can be increased or decreased.
- 15) Relevant literature/catalogue should be sent along with quotation.
- 16) **Negotiation shall not be held except with lowest bidder.**
- 17) Random testing of material on receipt in GGSSTP Store irrespective of the fact whether or not it was inspected before despatch shall be carried out by PSPCL. In case of any failure the entire lot shall be rejected at the risk and cost of the supplier.
- 18) Any deviation from PSPCL's standard terms and conditions be clearly mentioned in quotation under "**Schedule of deviations**" otherwise all terms and conditions will be deemed to have been accepted.
- 19) **Firm should mention GST number in their offer.**
- 20) The firm must mention HSN code of all items in their offer along with GST applicable on them. Uniform GST rates shall be applied while comparison of rates.
- 21) The location for the supply of goods/services must be in the territory of Punjab as goods are meant for use in Punjab.
- 22) Sourcing of service should be made from an agency with its office located in the territory of Punjab rather than merely from HQ of that agency. (which may be located outside the state).
- 23) **Tenders should enclose copies of Orders/Contracts against which they have supply same material to Thermal Plant of other states.**
- 24) Any firm which at the time of opening of the Tender enquiry, falls in any of the following categories, shall be regarded as defaulter and shall not be eligible for participation in any new Tender enquiry for a period of three years from the date of issue of Purchase Order in which it has defaulted:-
  - a) The Firm is a defaulter for the supply of 35% or more quantity on the date of expiry of the Contractual Delivery Period for the total ordered quantity.
  - b) The Firm is a defaulter for the supply of any quantity for more than 6 months from the date of expiry of the Contractual Delivery Period for the total ordered quantity.This clause shall be applicable item wise (all types, sizes and ratings) against which the firm has become defaulter under the above said conditions.
- 25) Payments can be made through RTGS system of Digital Payments instead of cheques to the suppliers/firms/contactors whosoever gives the consent. All the bank charges related to RTGS are to be borne by the suppliers/firms/contactors.
- 26) **Firm which are registered with MSME are required to provide their registration certificate along with quotation. Please also note Clause no. 30(a) of Annexure-'B'**
- 27) **All other terms and conditions are as per Annexure - 'B' attached.**

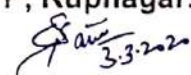
  
DY.CE/Monitoring  
GGSSTP, Rupnagar.  
  
3.3.2020



ANNEXURE-CSCHEDULE OF DEVIATIONS

(To be filled by tenderer)

Tenderer shall carefully state below any and all points in this proposal which are not in accordance with PSPCL's Technical Specification and the General Instructions:-

Sr. No.	Para no.	Technical Deviation, if any.
1.		
2.		
3.		
contd...		
Sr. No.	Para no.	General Deviation, if any.
1.		
2.		
3.		
contd...		

We hereby certify that the above mentioned are the only deviations from Purchaser's aforesaid specifications and general conditions.

Dated.

Authorized Signatory

Name: \_\_\_\_\_

Designation: \_\_\_\_\_

Address and Seal of the firm

**Note:** The tenderer is to clearly indicate any deviation in technical & general terms and conditions in this Annexure only. In case, the Technical Specification as well as General conditions of Tender Specifications are acceptable in toto, the word 'NIL' shall invariably be put in the above Columns. In case, nothing is mentioned here then it shall be presumed that there is no deviation in the offer and terms and conditions of the specifications are acceptable to the bidder in toto.

### Performa of pricing schedule

BREAK UP OF F.O.R. DESTINATION PER UNIT PRICE  
(THIS MUST ACCOMPANY THE TENDER DULY TYPED)

NAME OF TENDERER : \_\_\_\_\_

QUOTED QUANTITY : \_\_\_\_\_

NATURE OF PRICE : **FIRM**

A)	Break-up	(Rs.)
1.	Ex-works per unit price inclusive of packing forwarding (forming part of production) a) Cost of Major Component per item b) Cost of Minor Component per item. c) Cost of Labour charges per item. d) Overhead expenses per item. e) Packing charges forming part of production cost f) Any other charges	
2.	GST @ _____%	
3.	Sub total (1+2)	
4.	Packing cost (not forming part of production cost)	
5.	GST @ _____%	
6.	Sub total (4+5)	
7.	Forwarding charges.	
8.	GST @ _____%	
9.	Sub total (7+8)	
10.	Freight charges.	
11.	GST @ _____%	
12.	Sub total (10+11)	
13.	Insurance charges	
14.	GST @ _____%	
15.	Sub total (13+14)	
16.	Total (6+9+12+15)	
17.	All-inclusive FOR Destination per unit Rate (3+16)	

Note: 1. The firms should quote FIRM Prices only and offers of firms quoting variable prices shall be out rightly rejected

Name: \_\_\_\_\_

Designation: \_\_\_\_\_

Address and Seal of the firm

NOTES:

- i) If rate of GST in Para A is not given, the maximum applicable rate of GST, prevailing at the time of opening of tender, shall be taken into consideration.

*A*

- ii) The firms indicating NIL or concessional rate of GST in their tenders will have to absorb GST up to the full rate applicable at the time of tendering. The firm who do not agree to this stipulation or indicate GST as extra without indicating the applicable rate shall be loaded with maximum rate of GST for evaluation purpose.
- iii) In case quoted prices or any other declaration/ statement given in this annexure do not tally with the ones given in main tender or elsewhere, the ones given here shall be considered as the quoted price.
- iv) Any arithmetical error shall be considered to the advantage of the purchaser.
- v) The bidders shall not be allowed to indicate over all discount on the quoted price for which split up has been given. Any firm offering discount of the quoted price or after the opening of tender will be out rightly rejected.
- vi) The provisions of GST acts shall prevail upon wherever applicable in the terms and conditions of the specification.
- vii) The firm shall indicate the HSN code of each item.

**Item No.1 MULTIPLE PORT OUTLETS (MPO) FITTED WITH LINER FOR STG-III BOWL MILLS (TYPE HP-803).**

- i) MPOs shall be suitable for bowl mills (type HP-803) installed at Stg-III of GGSSTP, Ropar.
- ii) Approximate weight of this part shall be 185 Kgs.
- iii) MPO shall be manufactured from cast steel Grade-II conforming to IS: 4896-1992 having following composition.

Sr.No.	Description of Element	Min(%age)	Max(%age)
1.	Carbon	0.55	0.70
2.	Silicon	-	0.75
3.	Manganese	0.50	1.0
4.	Chromium	0.80	1.50
5.	Molybdenum	0.20	0.40
6.	Sulphur	-	0.04
7.	Phosphorus	-	0.04

- iv) Hardness of MPO shall be 330 to 380 BHN.
- v) Multiple port outlet liner shall be manufactured as per sketch (Annexure-II) and shall have chemical composition as per IS:4771, TYPE 1b Ni Hcr. 34/600 as given below:

Sr.No.	Description of Element	Min(%age)	Max(%age)
1.	Carbon	3.20	3.60
2.	Silicon	1.50	2.20
3.	Nickle	4.0	6.0
4.	Chromium	7.50%	9.50%
5.	Manganese	0.30	0.60
6.	Molybdenum	-	0.50
7.	Sulphur	-	0.15
8.	Phosphorus	-	0.30

- i) Hardness of these liners shall be 600 BHN (Minimum).  
Approximate weight of MPO liner shall be 17.8 Kgs.

**Item no. 2 Journal Skirt Assy. For HP-803 Stg-III**

- i) Journal Skirt Assy. Shall be manufactured as per drawing prepared by the manufacturer after seeing component at site. The material of journal skirt assy. shall be cast steel (Grade-II) conforming to IS: 4896-1992 having following composition.

Sr. No.	Description of Element	Min(%age)	Max(%age)
1.	Carbon	.55%	.70 %
2.	Silicon	-	0.75
3.	Manganese	.50%	1.0%
4.	Chromium	0.80 %	1.50%
5.	Molybdenum	0.20 %	0.40%
6.	Sulphur	-	0.05%
7.	Phosphorus	-	0.05 %

- ii) Journal Skirt Assy. should be suitable for BHEL Make HP-803 Bowl Mills installed at Stage-III.
- iii) The Hardness of Journal Skirt Assy. shall be 330 to 380 BHN.

2  
2-5

**NOTES:**

1. The drawing attached is rough sketches for the purpose of estimation only. Material shall be manufactured as per sample and shall be suitable for various applications as explained above.
2. Sample of these items can be seen at site and drawing shall be prepared by manufacturer himself and one copy of the drawing to be supplied to this office.
3. Sample if required can be collected by the manufacturer on the payment equivalent to quoted rates.
4. Chemical composition of material shall be got tested from NABL approved testing lab.
5. The manufacturers should have supplied these spares to thermal plants of 210MW or above capacity unit and should supply following information along with the quotations.
  - a) Name and location of the works where the goods shall be manufactured.
  - b) Testing facilities/infrastructure available at the works.
  - c) The details of latest supplies of same items of bowl mills to other power houses (Photocopies of Purchase order shall be attached).
6. Manufacturer shall ensure proper fitment against the existing ones and submit fitment warranty certificate.

ASE/RMI



Annexure - I

2  
3-5

Annexure - I

1-232  
10

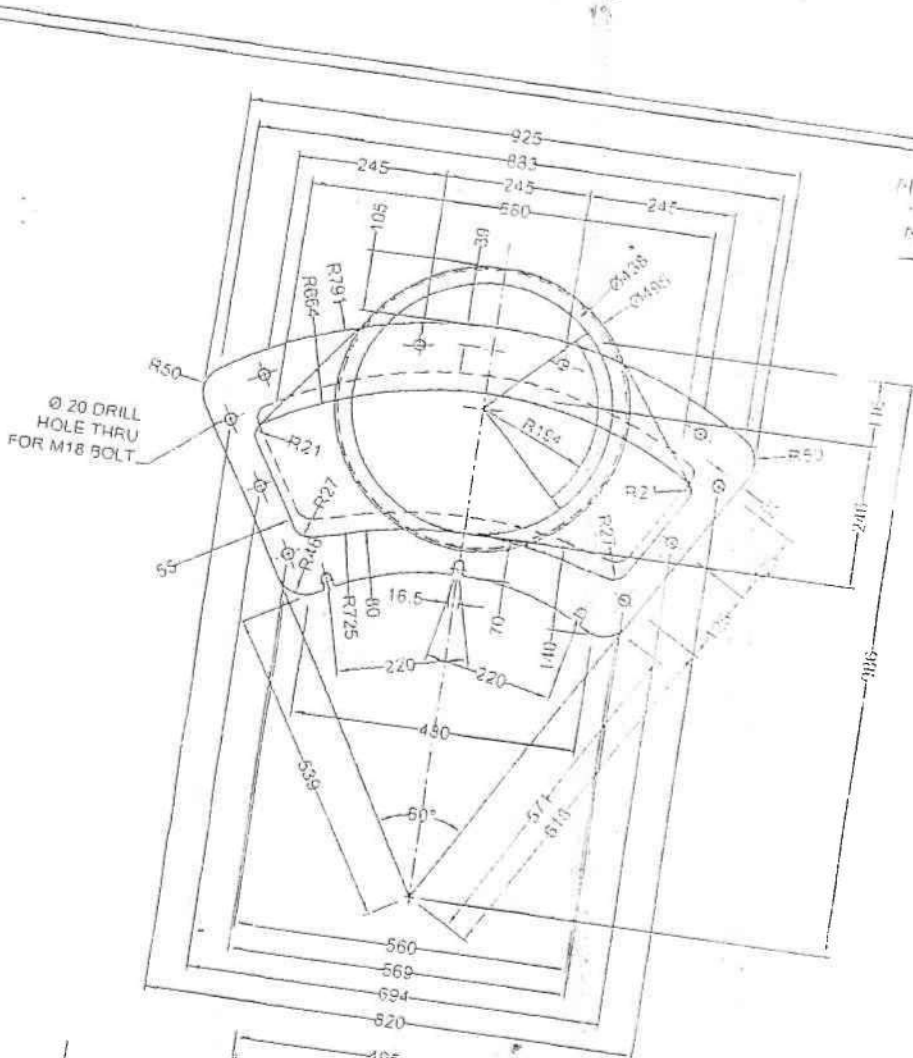

ROUGH SKETCH FOR  
MPO FOR HP-FUS STUDES  
MILLS

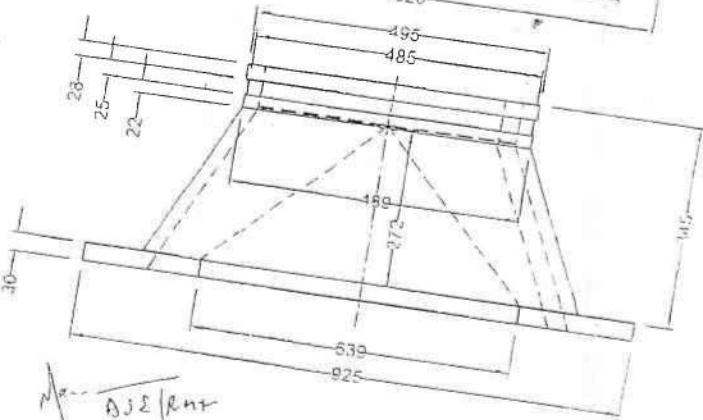

Mr. A.J.E/Ent

NOTE:- ALL DIMENSION ARE IN MM

Handwritten signature/initials.

Handwritten signature/initials.

Annexe II  
2-2

2  
45

32  
11

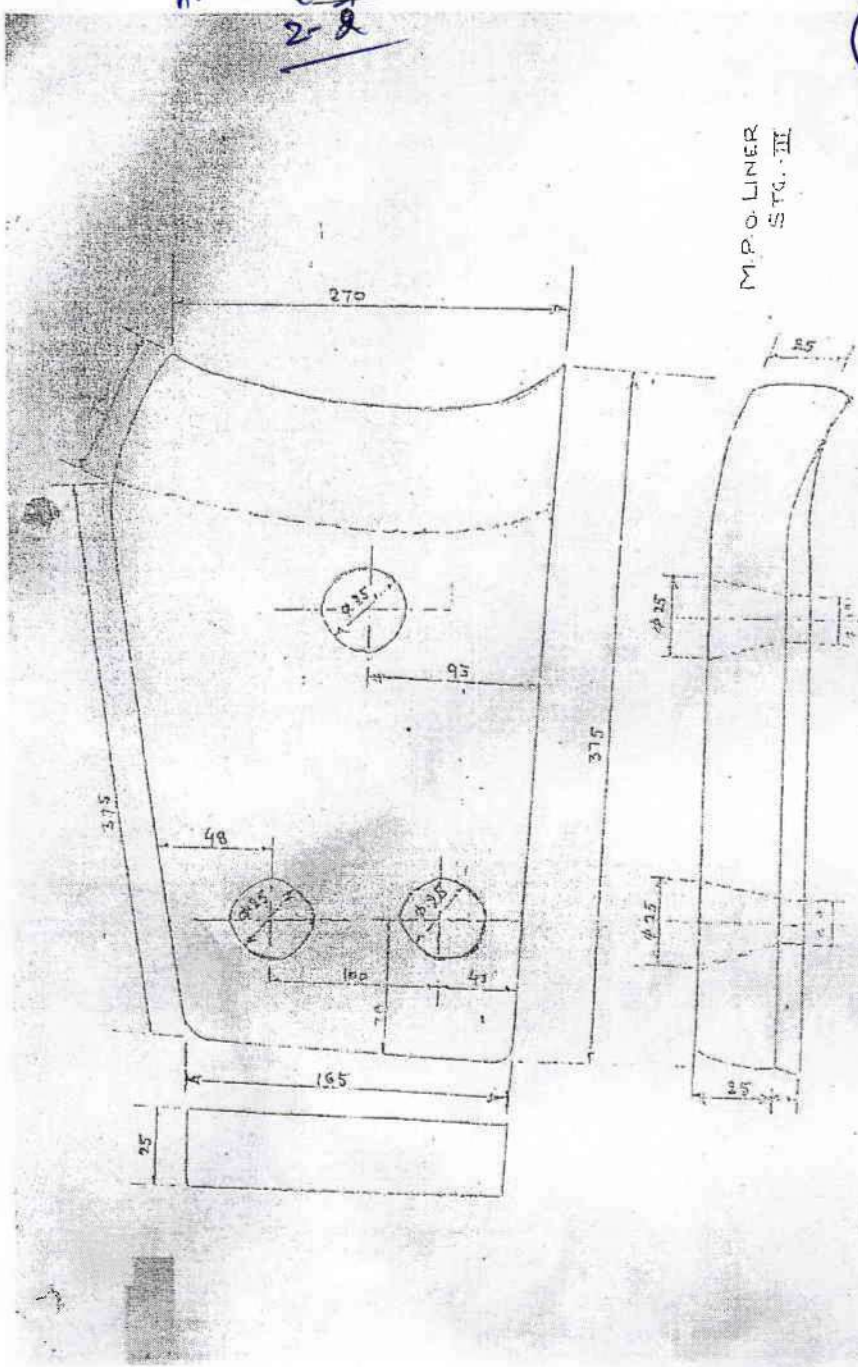

MPO LINER HP-803 MILLS  
MATERIAL NI-HARD

✓

2

ROUGH SKETCH FOR JOURNAL HEAD SKIRT

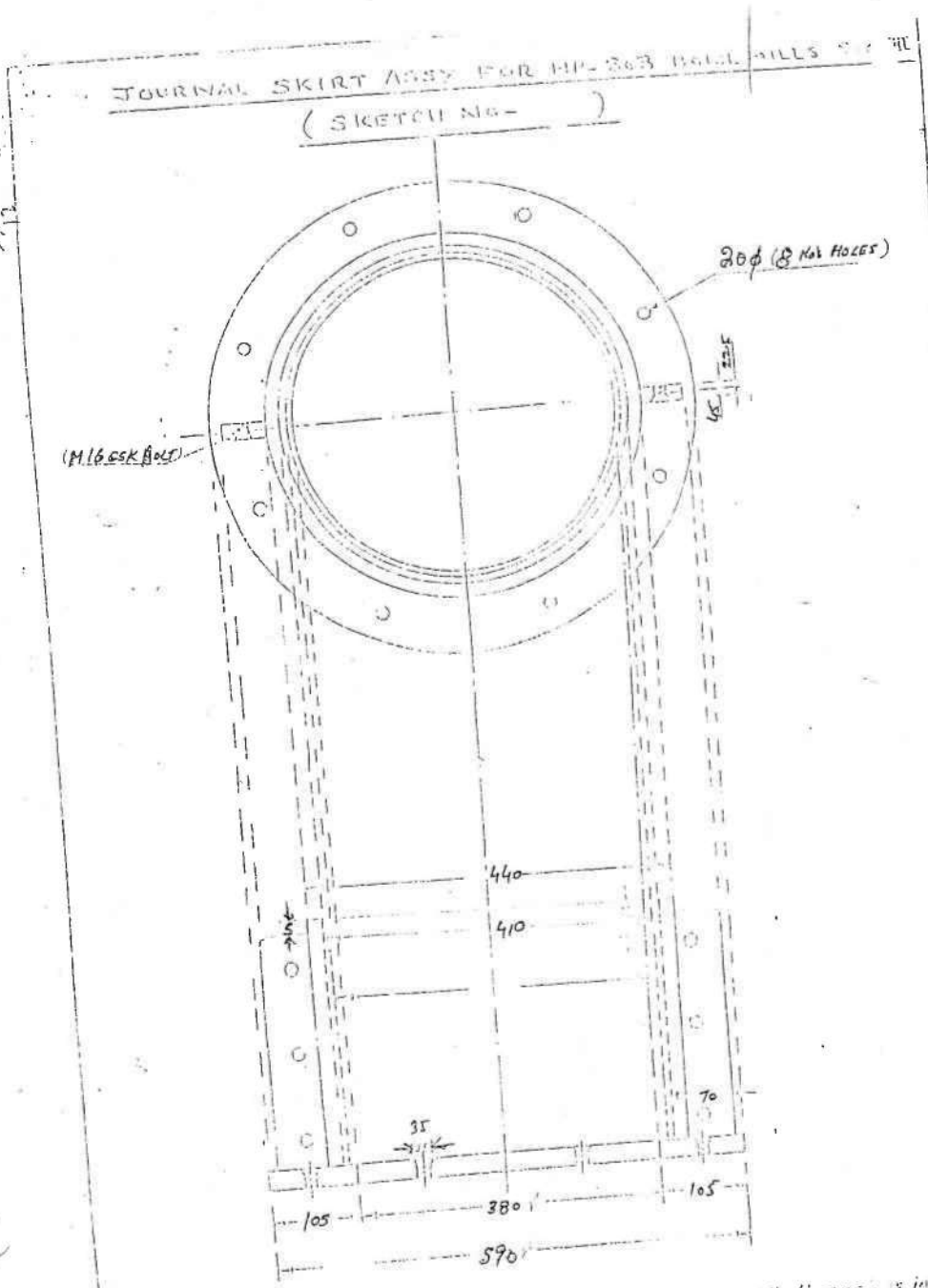

All dimensions in mm  
Dwg. No. to Scale

JOURNAL HEAD SKIRT - III

ANNEXURE - II

Handwritten signature and initials in blue ink.